

EN & CO.  
SHERS

LOANS ON  
DIAMONDS  
WATCHES  
JEWELRY  
No. 5

Y STATE  
AN CO.

S AND MINERS  
TATION CO.

TRANS ATLANTIC  
RAILWAY

HENRY C. LOGEMANN,  
REAL ESTATE BROKER

SAVE  
THE S

M.E. WOLFE • WHOLESALE

PAPERS  
LEAD PENS  
STATES  
STATIONERS  
JEWELRY  
FANCY GOODS  
FINE WRITING  
PAPERS

MERCA NTILE  
AGE NCY

Various  
Wedg  
Litho  
Ceram  
New  
and  
CELEBRATED  
MEXICO'S  
SOLDIERS

MERCA NTILE  
AGE NCY

NIWATHA HOTEL

CLOTHING  
CRED

DRUMPTON  
NORTHAMPTON  
ACADEMY

C.T. DAILY & CO.  
IMPORTERS

C.T. DAILY & CO.  
IMPORTERS

GREGORY H. U.





DINING SALOON

KNICKERBOCKER  
HOTEL  
FINE  
&  
RESTAURANT

FINE  
CONCERT  
THEATRE  
STREET  
THEATRE

DRINK  
WATER  
LITTLE  
COLD

WELL  
KNICKERBOCKER  
HOTEL

WELL  
KNICKERBOCKER  
HOTEL

METROPOLITAN LUNCH  
THE MARKET LUNCH STAND IN NEW YORK

KNICKERBOCKER HOTEL

PIANOS & ORGANS  
1760 SHEET MUSIC STORE

IN THE  
LUNCHSTAND

STAR  
SIDE

KNICKERBOCKER HOTEL







H

H

H

H

H

LUNCH  
AND OF NEW YORK

STAR  
SHOE  
SHINE  
5

KNICKERBOCKER HOTEL

HOTEL

PIANOS  
Broadway

STREET  
MUSEUM

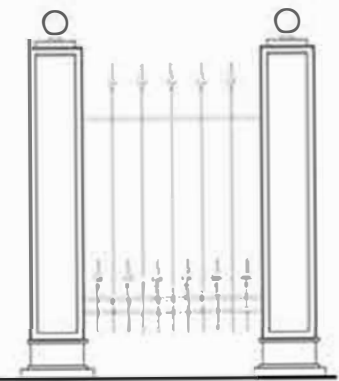

20 FENCE SIDE ELEVATION  
SCALE: 3/4" = 1'-0"

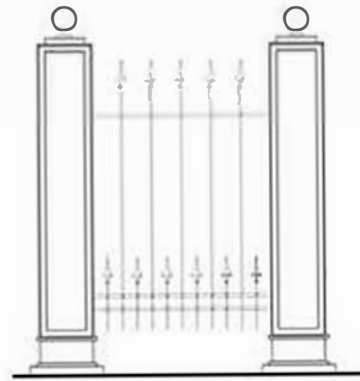

21 FENCE SIDE ELEVATION  
SCALE: 3/4" = 1'-0"

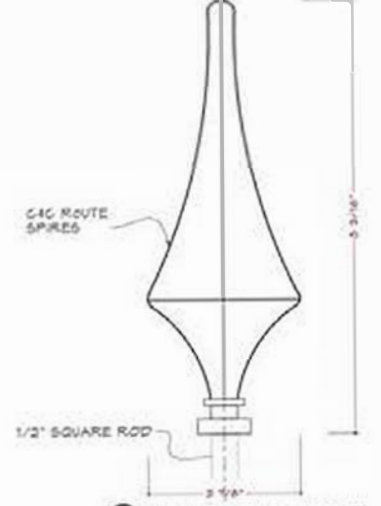

22 FINAL DETAIL (FULL SCALE)  
SCALE: 1:1

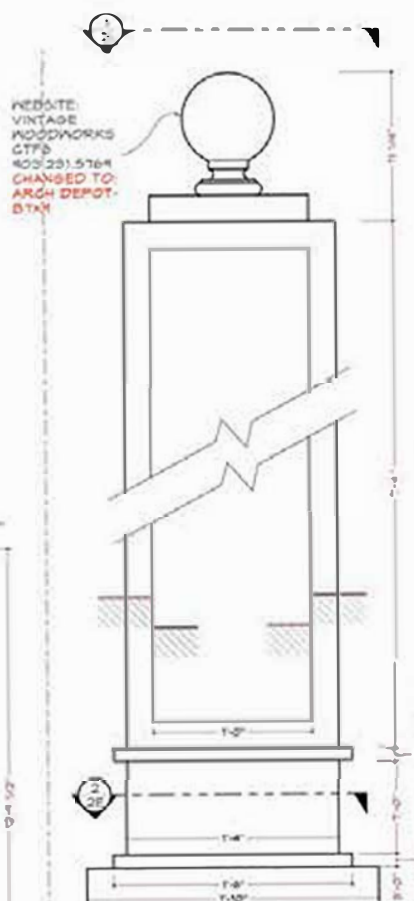

23 POST ELEVATION  
SCALE: 3/4" = 1'-0"

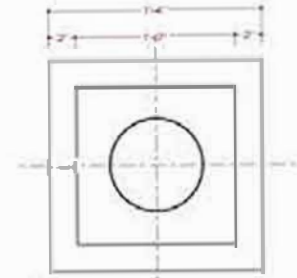

24 POST TOP VIEW  
SCALE: 3/4" = 1'-0"

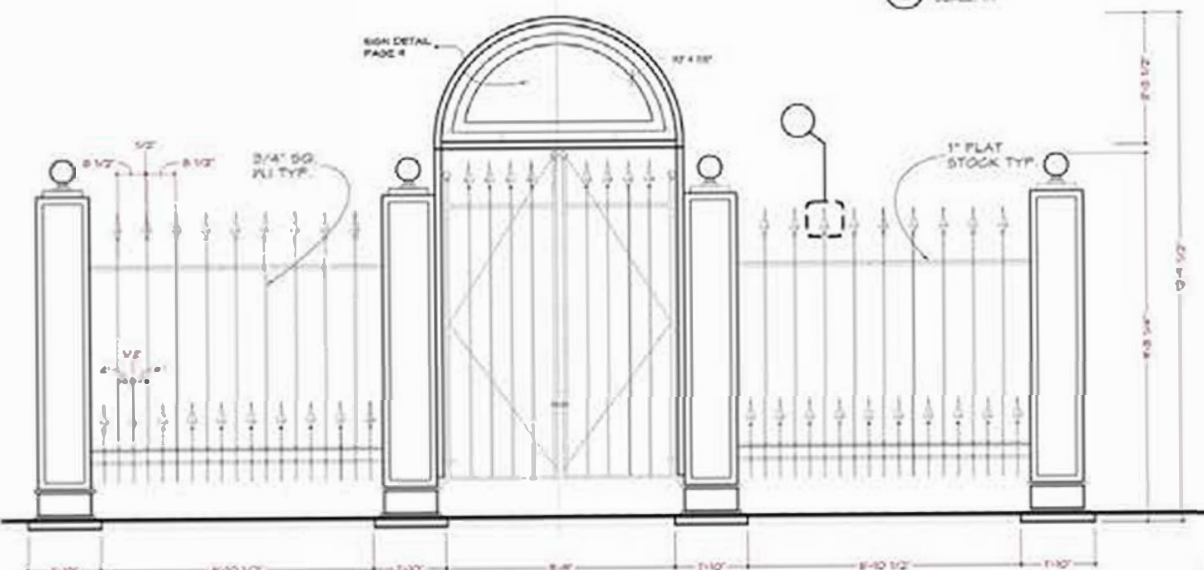

25 FENCE ELEVATION  
SCALE: 3/4" = 1'-0"

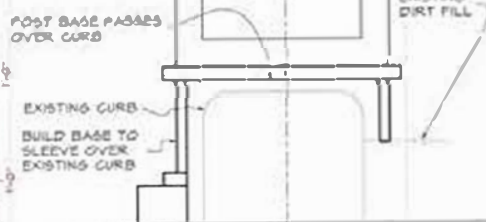

26 POST BASE  
SCALE: 3/4" = 1'-0"

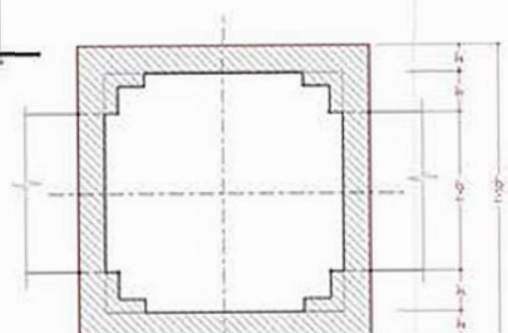

27 POST BASE  
SCALE: 3/4" = 1'-0"

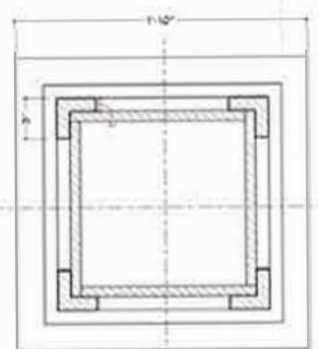

28 POST SECTION  
SCALE: 3/4" = 1'-0"

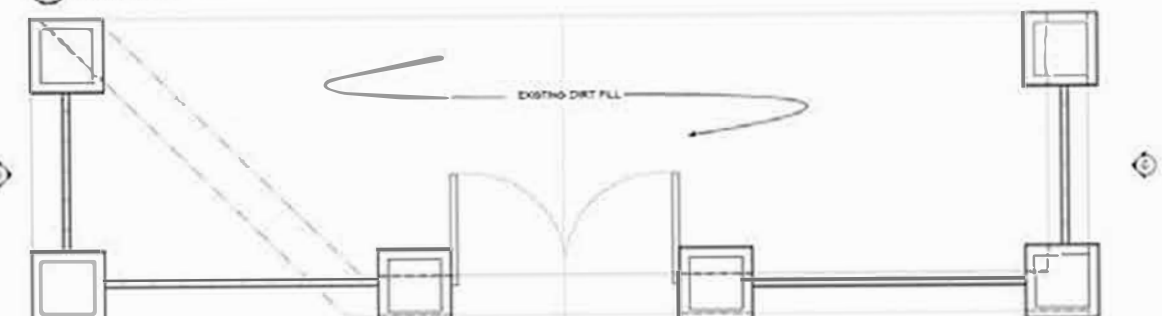

29 FENCE PLAN  
SCALE: 3/4" = 1'-0"

REBSITE: VINTAGE WOODWORKS GTPS 400 231 5764 CHANGED TO ARCH DEPOT 874M

|  |                          |     |
|--|--------------------------|-----|
|  | BY STREET'S LAWRENCE     | 200 |
|  | LAWRENCE, MA             |     |
|  | EXHIBITION DATE          |     |
|  | 200 ARLETTY HALL PREMISE |     |
|  | MASSA WARR 48 18         | 00  |

RELEASED

# SURVEYING

# CURRENCY EXCHANGE

# TRAVEL

NOTE!  
ALL SIGNS TO BE BUILT  
FLAT (NO FRAME)  
SO AS TO ALLOW A  
PRINTING SURFACE

GRAPHICS OR SCENIC DESIGN  
SHOULD INDICATE A FRAME IN  
DESIGN

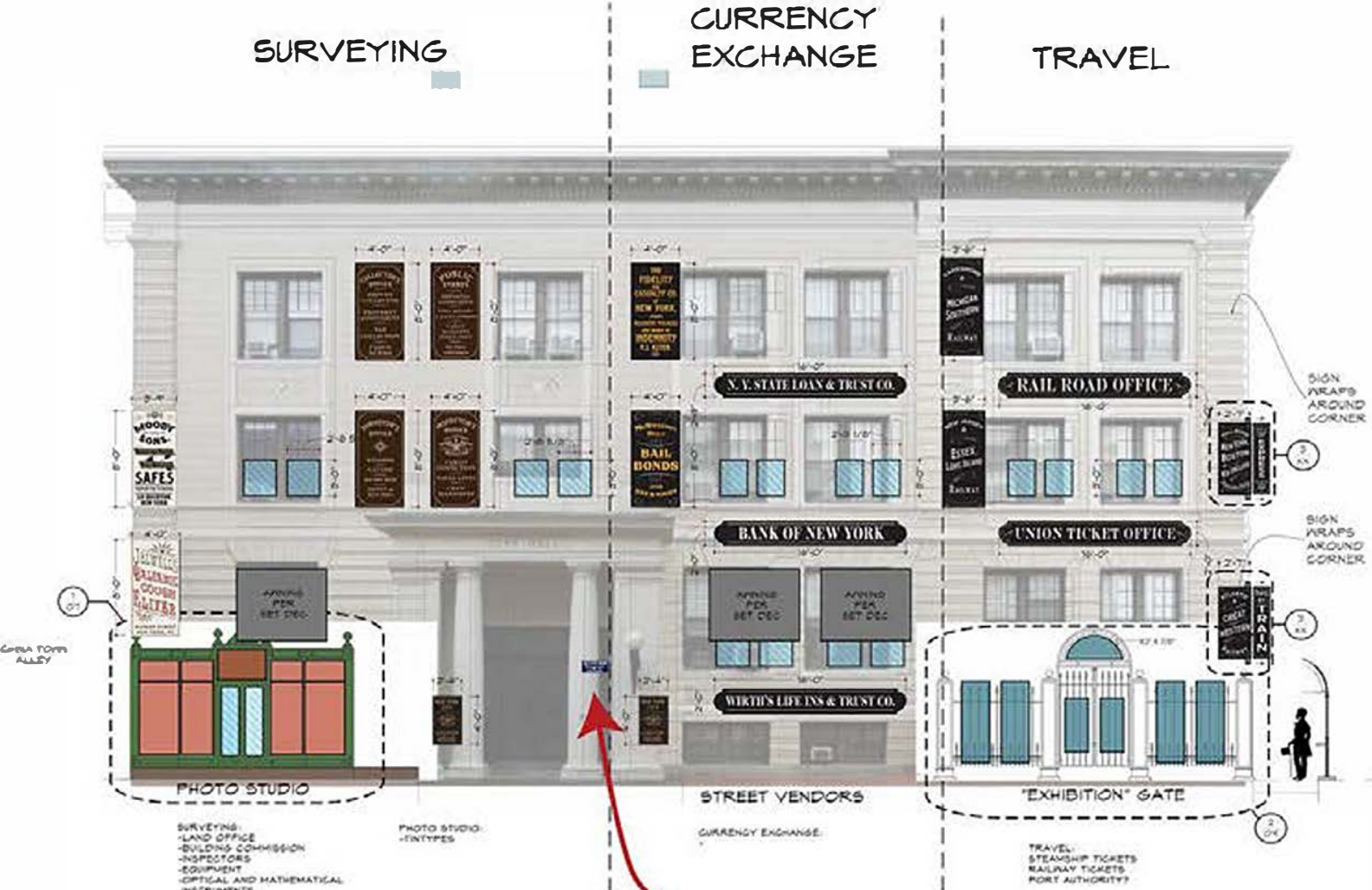

SIGN WRAPS AROUND CORNER

SIGN WRAPS AROUND CORNER

2' X 4'

3' X 4'

2' X 4'

GREEN FORM ALLEY



**Western union sign to be placed as needed either on corner or in entry way area.**

|  |                              |
|--|------------------------------|
|  | APRNS                        |
|  | OPPORTUNITY FOR MODERN DECOR |
|  | UNIVERSITY RELATED SIGNAGE   |
|  | CURRENCY RELATED SIGNAGE     |
|  | TRAVEL RELATED SIGNAGE       |
|  | PHOTO STUDIO SIGNAGE         |
|  | CUSTOMER HOUSE SIGNAGE       |

A WEST ELEVATION - BLDG. @ (CITY HALL) SIDE  
SCALE: 1/4" = 1'-0"



TRAVEL

CITY HALL

SHORT HAND ACADEMY



TRAVEL TOPICS TO INCLUDE IN SIGNAGE:

CITY HALL RELATED TOPICS TO INCLUDE IN SIGNAGE:  
 DEPARTMENT OF BUILDINGS  
 DEPARTMENT OF RECORDS  
 CITY CLERK'S OFFICE  
 MARRIAGE LICENSES  
 DEATH CERTIFICATES  
 BIRTH

SHORT HAND ACADEMY RELATED TOPICS TO INCLUDE IN SIGNAGE:  
 PITMAN SHORTHAND (MOST POPULAR STYLE AT THE TIME)  
 CORRESPONDENCE COURSES OFFERED

A SOUTH ELEVATION - BLDG. 6 (CITY HALL) SIDE  
 SCALE: 1/4" = 1'-0"

Western union sign to be placed as needed either on corner or in entry way area - perpendicular to the wall.

NOTE!  
 ALL SIGNS TO BE BUILT FLAT (NO FRAME) SO AS TO ALLOW A PRINTING SURFACE

GRAPHICS OR SCENIC DESIGN SHOULD INDICATE A FRAME IN DESIGN

|  |                                     |
|--|-------------------------------------|
|  | ANNING                              |
|  | OPPORTUNITY FOR WINDOW DECAL        |
|  | TRAVEL RELATED SIGNAGE              |
|  | TRAVEL RELATED SIGNAGE (ON PERGOLA) |
|  | CITY HALL RELATED SIGNAGE           |
|  | SHORT HAND ACADEMY                  |



A SOUTH ELEVATION - BLDG. 6 (CITY HALL) FENCE ELEVATION  
 SCALE: 3/4" = 1'-0"

RELEASED  
 4.10.18

|  |   |
|--|---|
|  | 111 STREET'S LAWRENCE<br>LAWRENCE, MA 01840<br>CITY HALL SIGNAGE<br>4.10.18<br>12 |
|--|---|

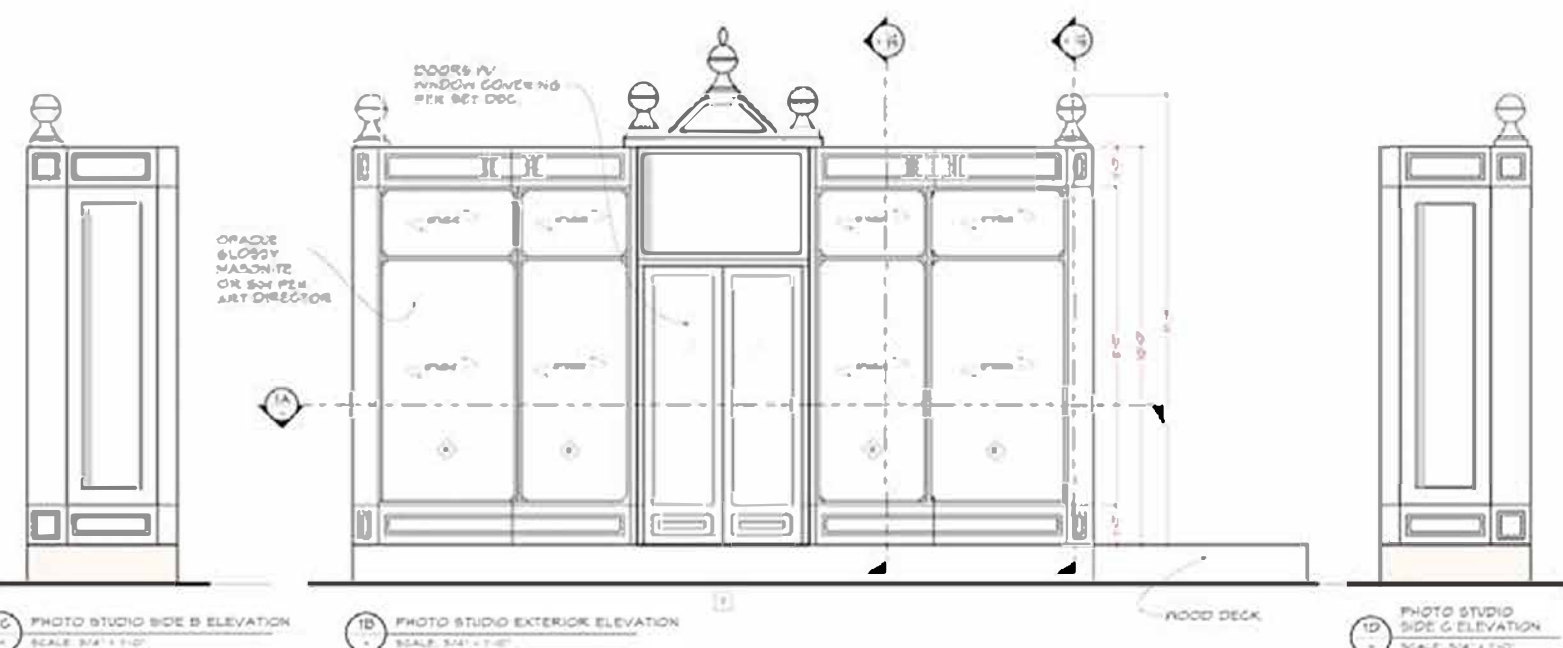

1C PHOTO STUDIO SIDE B ELEVATION  
SCALE 3/4" = 1'-0"

1B PHOTO STUDIO EXTERIOR ELEVATION  
SCALE 3/4" = 1'-0"

1D PHOTO STUDIO SIDE G ELEVATION  
SCALE 3/4" = 1'-0"

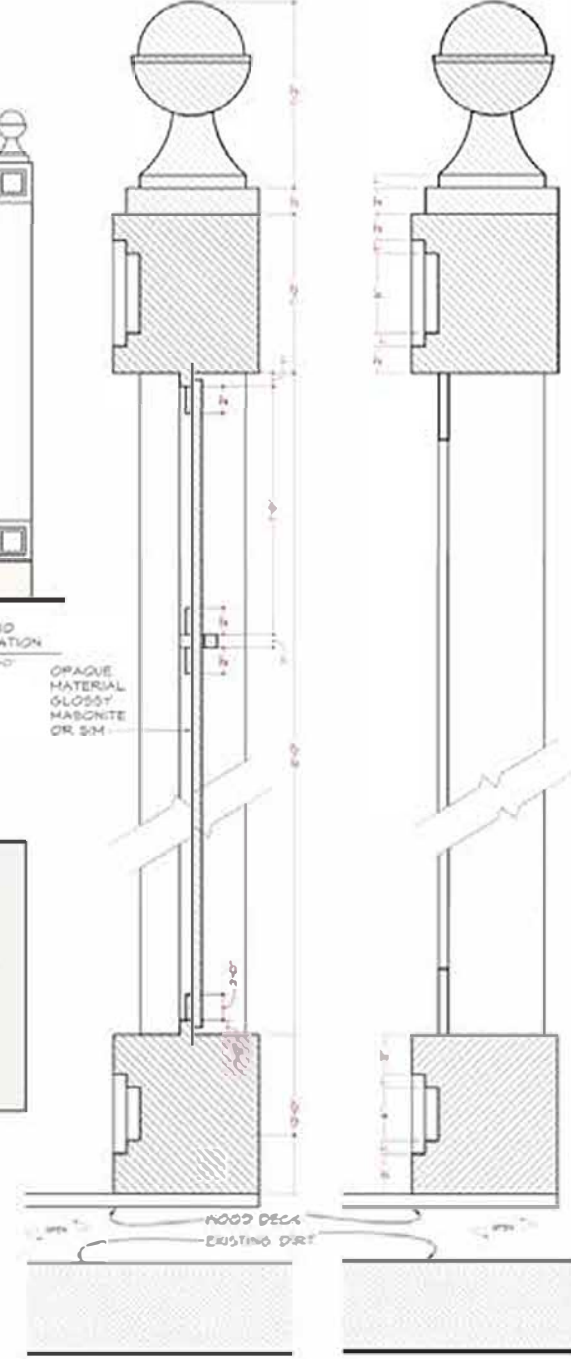

1E BUILDING SECTION  
SCALE 3/4" = 1'-0"

1F BUILDING SECTION  
SCALE 3/4" = 1'-0"

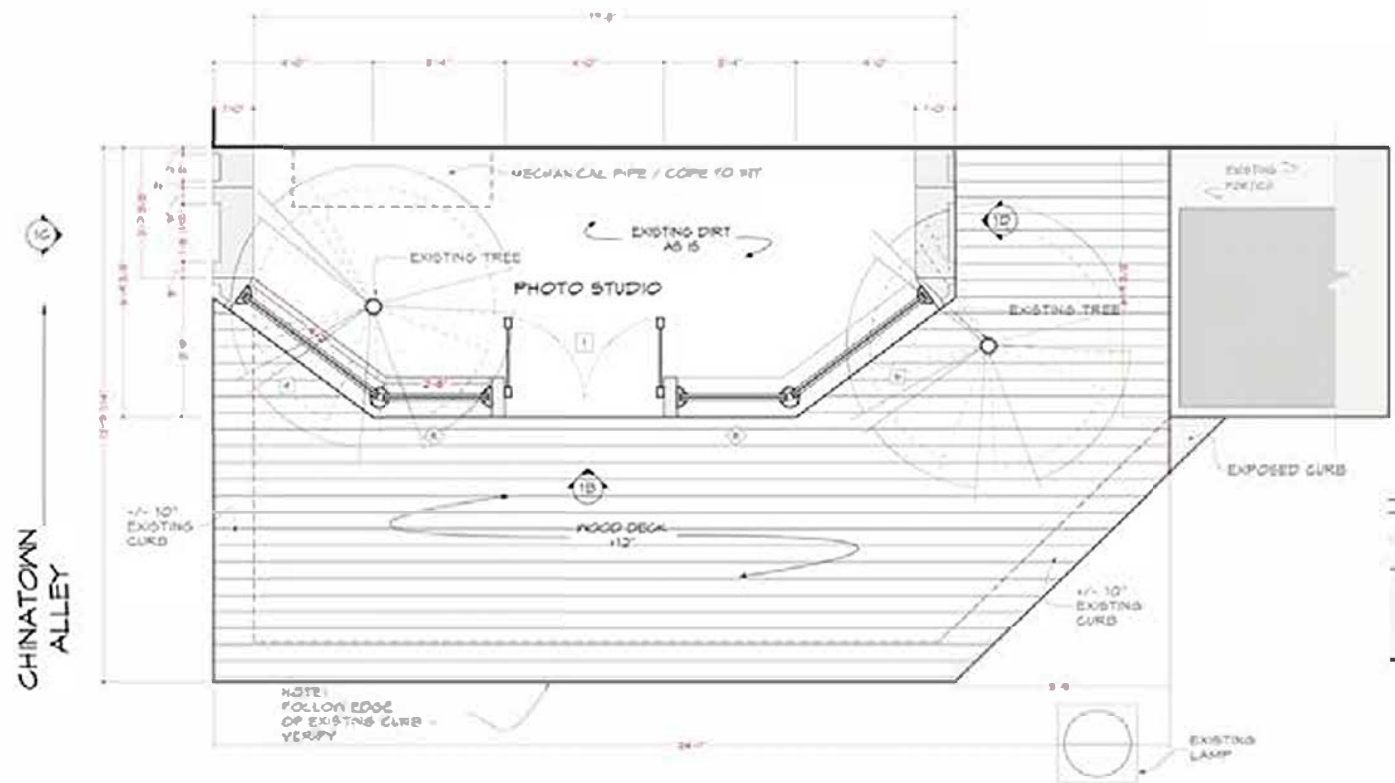

1A PHOTO STUDIO PLAN  
SCALE 3/4" = 1'-0"

CHINATOWN ALLEY

RELEASED



|                     |     |
|---------------------|-----|
| BY SAIZETS LAWRENCE | 000 |
| LAWRENCE 118        |     |
| PHOTO STUDIO        |     |
| ALL RIGHTS RESERVED |     |
| DATE PLOTTED 4/8/18 | 06  |

**METROPOLITAN LUNCH**  
THE OLDEST LUNCH STAND IN NEW YORK

COFFEE 2  
HOT FRANKFURTER 2  
ICE CREAM 3  
SODA 2  
CAKES 3  
HOT FRANKFURTER 2

**THE OLDE LUNCHSTAND**  
COFFEE 2  
HOT FRANKFURTER 2  
ICE CREAM 3  
SODA 2  
CAKES 3

**KNICKERBOCKER HOTEL**

HOTEL

**PIANOS & ORGANS**

**1760 SELECTIONS POPULAR SHEET MUSIC** 5¢ per copy

PIANOS MELODEONS CULCIMERS HARPICHOORDS ORGANS

120

PIANO FORTE - 10 - LET  
1760 SELECTIONS POPULAR SHEET MUSIC  
EXCELLENT INSTRUMENTS - 10 - LET



**INSPECTOR'S OFFICE**  
 PUBLIC STORES  
 INSPECTOR'S OFFICE  
 CARROLL INSPECTION  
 N. B. ALLEN  
 175 N. 5TH ST.

MOHAWK RAILWAY  
 TROOPERS RAILWAY

HUDSON RIVER  
 TICKET OFFICE  
 MOHAWK R  
 TICKET OFF

FALL RIVER  
 NEW YORK  
 BOSTON  
 & NEW ENGLAND  
 Steamship

NEW YORK  
 TROY,  
 ALBANY  
 STEAM BOAT  
 FROM MONDAY  
 WEDNESDAY  
 & FRIDAY

RAIL ROAD OFF  
 UNION TICKET OFF

ATLANTIC  
 &  
 GREAT  
 WESTERN  
 Railway

TRAVEL  
 BY  
 TRAIN

N.Y. CENTRAL  
 &  
 HUDSON  
 RIVER  
 Railroad



POST OFFICE - COMMON COUNCIL CHAMBERS  
 BUDGET OFFICE - CLERK'S OFFICE - LICENSING  
 MAYOR'S OFFICE - MEETING HALL - LIBRARY  
 SHERIFF'S OFFICE - DEPARTMENT OF RECORDS

**POST OFFICE**  
 PITMAN'S SHOP TRAND &  
 CORRESPONDENCE COURSE

**OMNIBUS LINE OFFICE**

SHORTLAND

N. Y. STATE LOAN & TRUST CO.  
 WIRTH'S LIFE INS & TRUST CO.  
 BANK OF NEW YORK

TELEGRAPH  
 CHECKING OFFICE

DISTRICT  
 MESSENGER  
 COMPANY  
 ALL HOURS  
 DAY & NIGHT

TELEGRAPH CO.  
 AND  
 DISTRICT  
 MESSENGER CO.  
 LOW RATES  
 QUICK SERVICE

HORACE'S  
 SMOKE SHOP  
 CIGARS  
 CIGARETTES  
 AND  
 SOFT DRINKS

FOUNTAIN  
 SALOON  
 & PARLOR  
 EST. 1848

LADIES  
 - AND -  
 GENTS  
 SHINING  
 - PARLOR

THE  
 FIDELITY  
 INSURANCE CO.  
 OF  
 NEW YORK,  
 AND  
 POLICE  
 AND  
 FINANCIAL  
 CITY

McSWEENEY  
 BAIL  
 BONDS  
 OPEN  
 DAY & NIGHT



FAMILY GROUPS

MINIATURES

TALBOTYPES

D. APPLETON & CO  
PRODUCERS & IMPORTERS  
OF  
STEREOSCOPIC  
PICTURES

AMBROTYPES

PORTRAITS

SUN-PAINTING

PORTRAITS OF  
THE DECEASED  
A SPECIALTY.

PICTURES  
TAKEN IN ANY  
WEATHER.

FREE  
ADMISSION  
MODERATE  
PRICES

ENTRANCE

ENTRANCE

FREE  
ADMISSION  
MODERATE  
PRICES

HIGHEST  
PERFECTION  
GUARANTEED

LIVENESS  
TAKEN IN A FEW  
SECONDS.

N. S. HAYDEN  
PHOTOGRAPHER  
AND  
LITHOGRAPHER  
125  
N. 5TH ST.  
PHILADELPHIA  
PA.  
HE HAS PHOTOGRAPHS OF  
ADULTS & CHILDREN  
INDIVIDUALS, AND IN  
DECEASED PERSONS  
TAKEN AT THEIR HOMES  
OR AT  
PRIVATE RESIDENCES.

STEREOSCOPIC  
VIEWS

|  |  |
|--|--|
|  |  |
|  |  |
|  |  |
|  |  |
|  |  |
|  |  |
|  |  |
|  |  |
|  |  |
|  |  |

\$1.50

DAGUERROTYPES  
TAKEN AND  
NEGATIVES MADE  
IN HANDMADE  
WOODEN  
FRAMES

\$2.50

\$1.50

DAGUERROTYPES  
TAKEN AND  
NEGATIVES MADE  
IN HANDMADE  
WOODEN  
FRAMES

\$2.50

DAGUERROTYPIC  
GALLERY

|  |  |
|--|--|
|  |  |
|  |  |
|  |  |
|  |  |
|  |  |
|  |  |
|  |  |
|  |  |
|  |  |
|  |  |

PORTRAITS OF  
BELOVED ONES  
TAKEN IN A  
FEW MINUTES

105

HE HAS PHOTOGRAPHS  
TAKEN AT THEIR HOMES  
OR AT  
PRIVATE RESIDENCES.



LITTLE WOMEN • NEW YORK STREET • PHOTO STUDIO/GALLERY • EXTERIOR ELEVATIONS • GRAPHICS • V.01  
 DATE: 09/11/18 • SCALE: 1/2" = 7'-0"

Geography44

















COLOR ELEVATION • PARLOR WINDOW WALL • V.02  
DATE: 09/17/18 • SCALE: 1" = 1' - 0"



















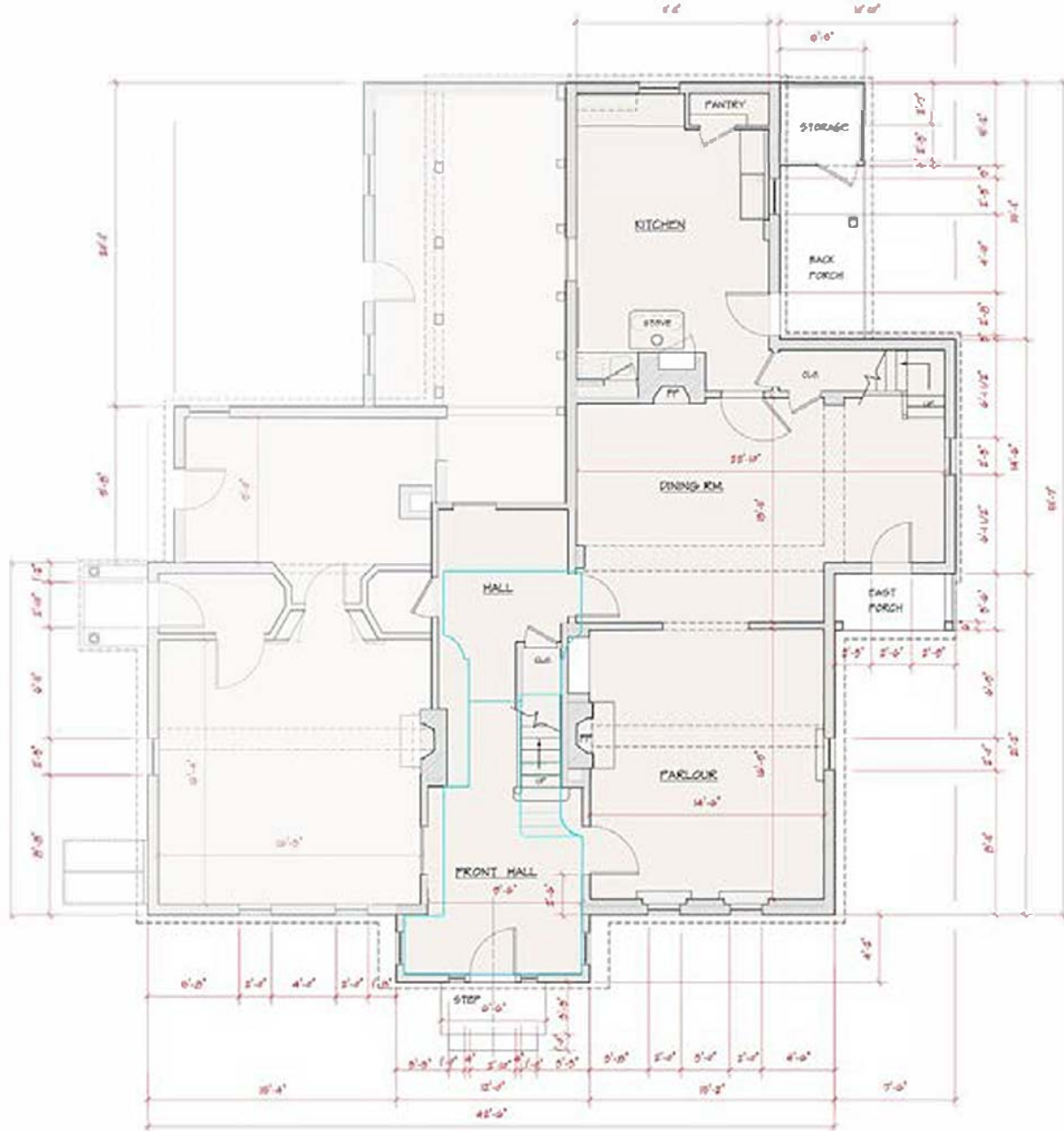

NORTH  
 ↑  
 PLAN - INT. MARCH HOUSE 1st FLOOR  
 Scale: 1/4" = 1'-0"  
 0 20 40 60 80 FT

ALT. HALLWAY I PLAN

07/18/18

PRELIMINARY

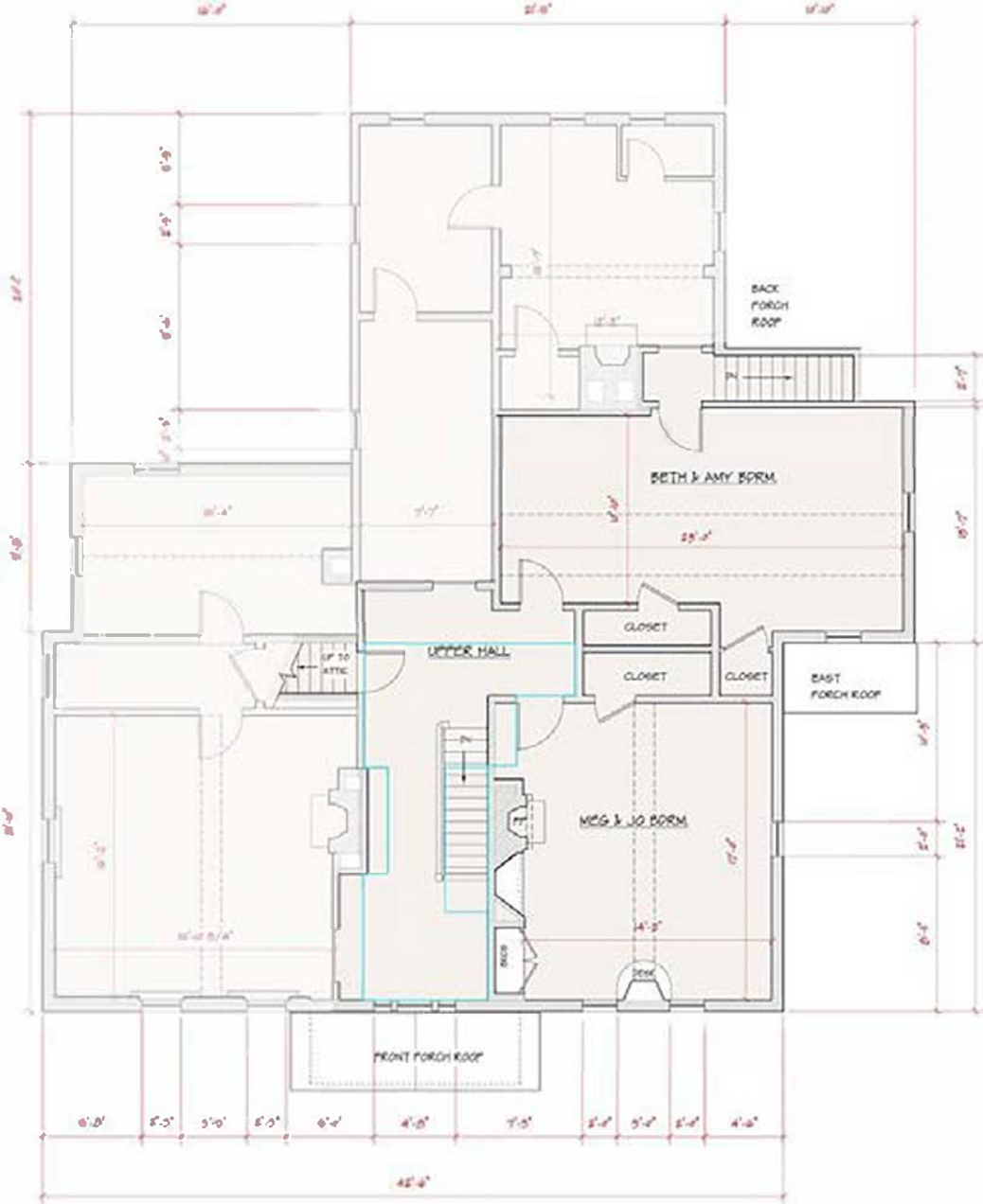

PLAN - INT. MARCH HOUSE 2nd FLOOR

Scale: 1/4" = 1'-0"



ALT. HALLWAY I PLAN

07/10/10

PRELIMINARY

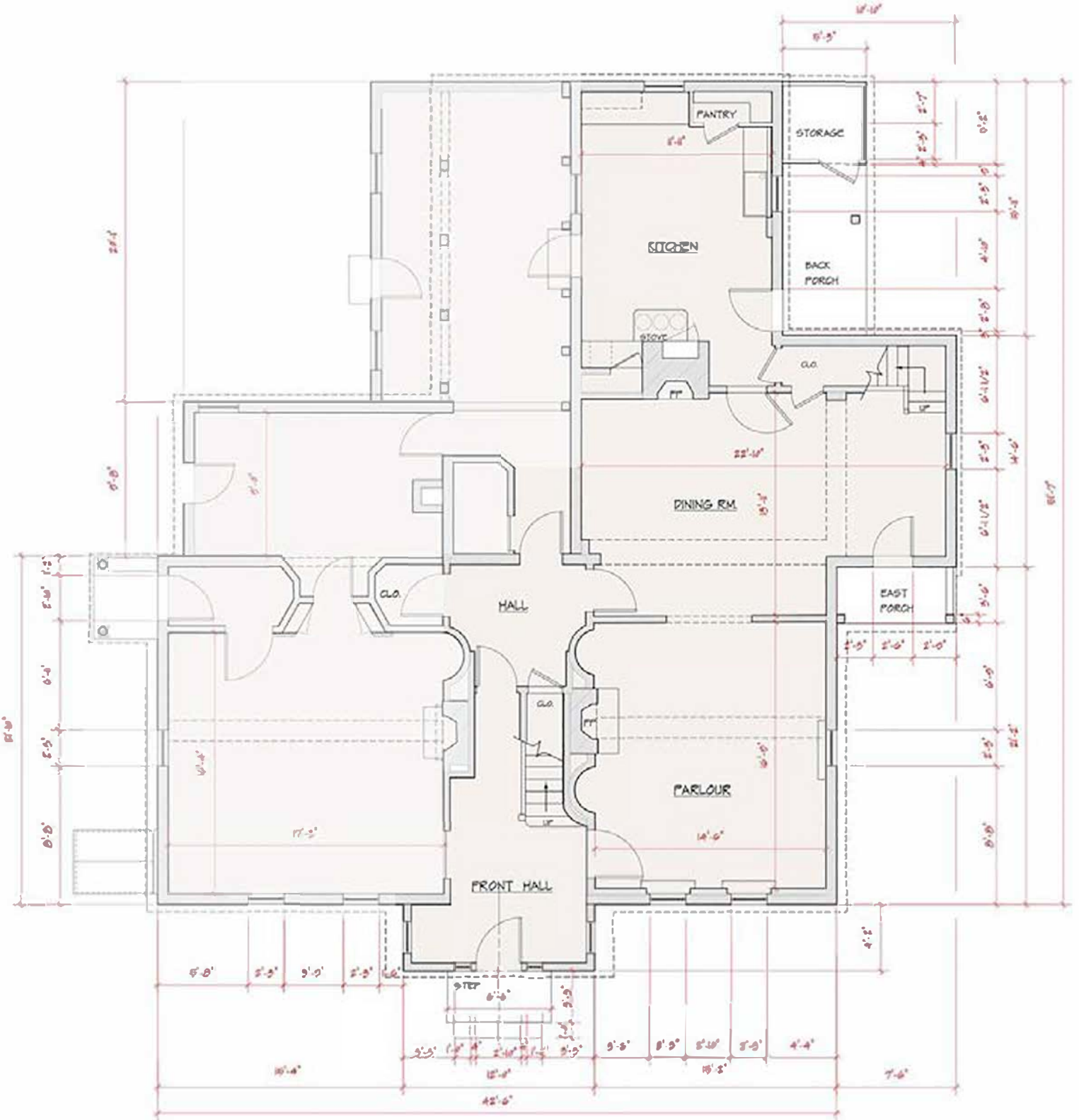



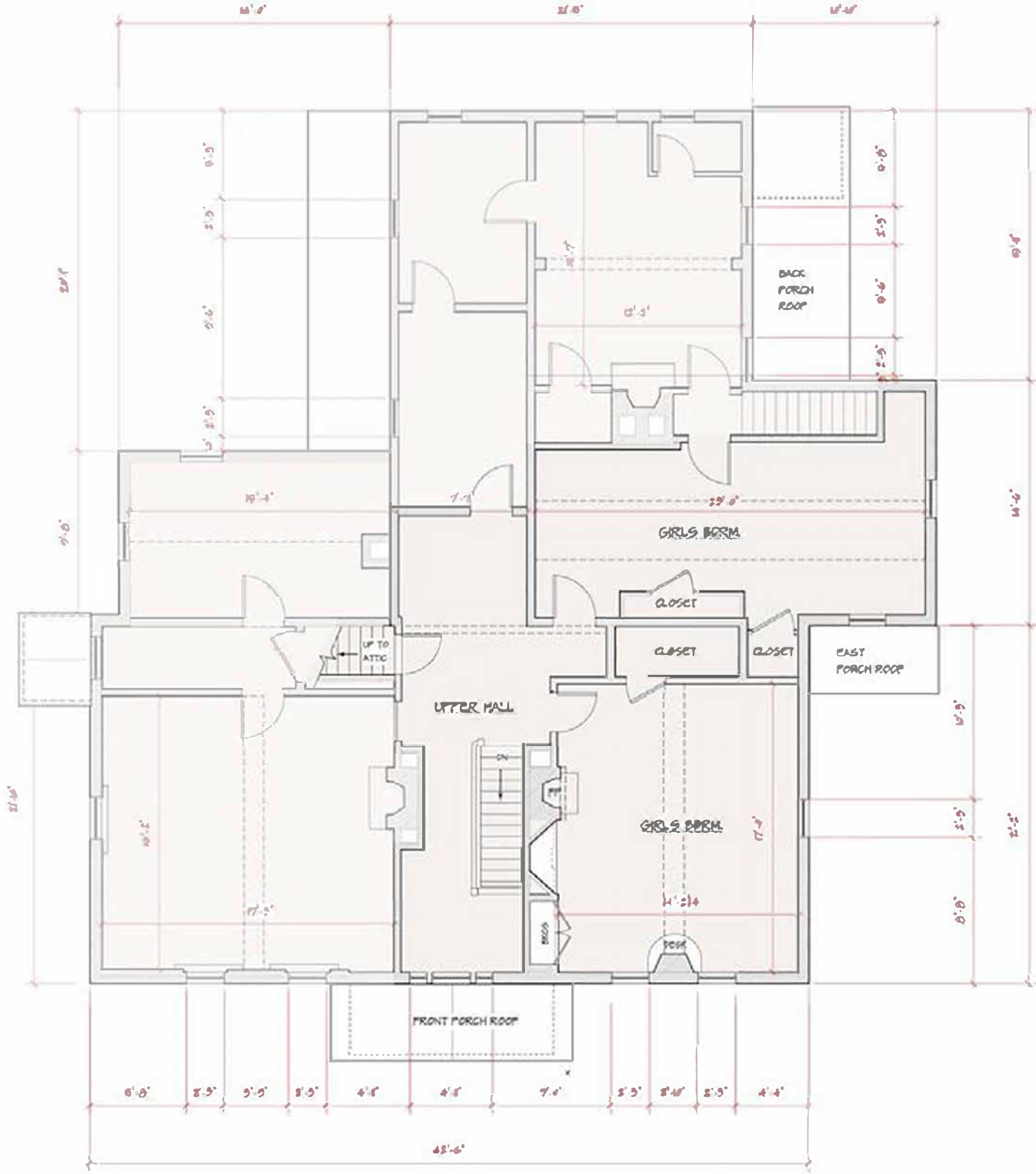



SOUTH EXT. ELEVATION

Scale:  $1/4" = 1'-0"$



B

EAST EXT. ELEVATION

Scale:  $1/4" = 1'-0"$



**D** WEST EXT. ELEVATION  
Scale: 1/4" = 1'-0"

07/17/18

PRELIMINARY

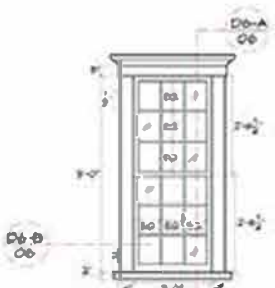

D0-A  
EXT. MARCH HOUSE TYP. WINDOW OVER 2ND FLOOR ELEV.  
SCALE: 1/2" = 1'-0"

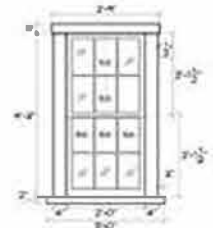

D0-B  
EXT. MARCH HOUSE TYP. WINDOW OVER 2ND FLOOR ELEV.  
SCALE: 1/2" = 1'-0"

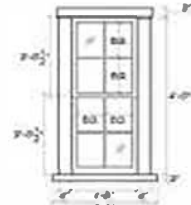

D0-C  
EXT. MARCH HOUSE TYP. WINDOW OVER 2ND FLOOR ELEV.  
SCALE: 1/2" = 1'-0"

- D0:  
- MAKE 10  
- PAINT GRADE  
- PAINT TBD

- D0:  
- MAKE 21  
- PAINT GRADE  
- PAINT TBD

- D0:  
- MAKE 05  
- PAINT GRADE  
- PAINT TBD

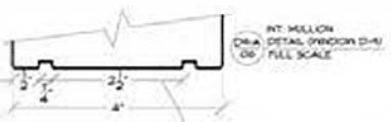

D0-A  
INT. MELLON  
D0-A DETAIL WINDOW SILL  
SCALE: FULL SCALE



D0-D  
EXT. MARCH HOUSE SECOND FLOOR WINDOW WITH SILL ELEV.  
SCALE: 1/2" = 1'-0"

- D0:  
- MAKE 01 SET  
- PAINT GRADE  
- PAINT TBD

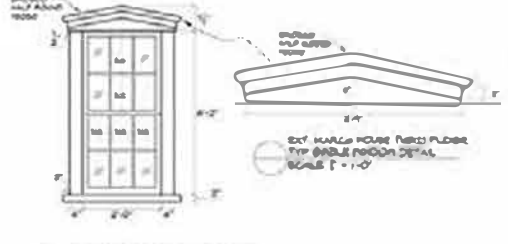

D0-E  
EXT. MARCH HOUSE THIRD FLOOR WINDOW WITH SILL ELEV.  
SCALE: 1/2" = 1'-0"

- D0:  
- MAKE 02  
- PAINT GRADE  
- PAINT TBD

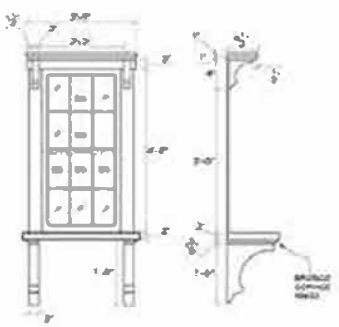

D0-F  
EXT. MARCH HOUSE SECOND FLOOR WINDOW WITH SILL ELEV.  
SCALE: 1/2" = 1'-0"

- D0:  
- MAKE 01  
- PAINT GRADE  
- PAINT TBD

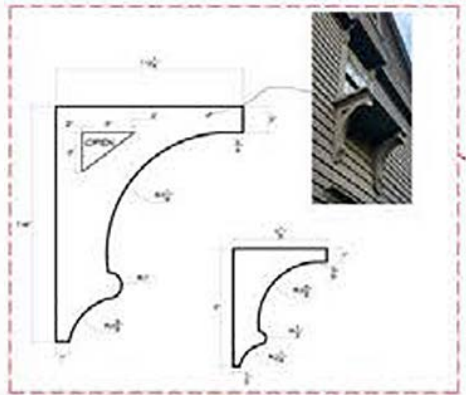

D0-A  
EXT. MARCH HOUSE SECOND FLOOR WINDOW WITH SILL ELEV.  
SCALE: 1/2" = 1'-0"

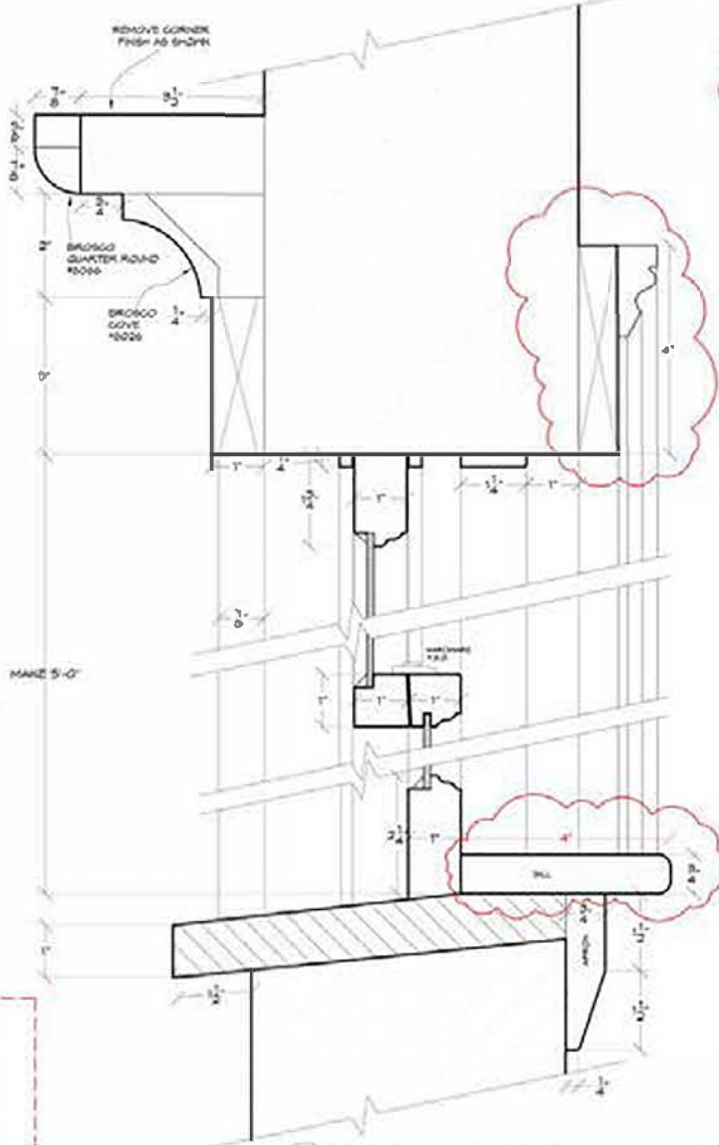

D0-A  
EXT. MARCH HOUSE TYP. WINDOW VERTICAL SECTION  
SCALE: 1/2" = 1'-0"

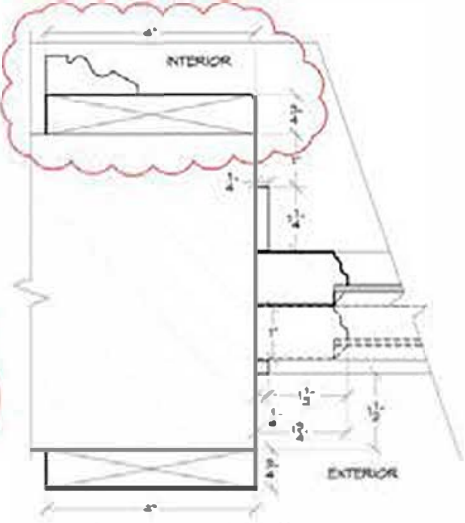

D0-B  
EXT. MARCH HOUSE TYP. WINDOW VERTICAL SECTION  
SCALE: 1/2" = 1'-0"



EXT. MARCH HOUSE  
KEEP PHOTO FROM FLOOR  
NOT TO SCALE!

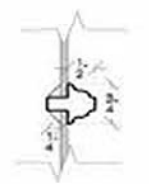

EXT. MARCH HOUSE  
TYP. WINDOW DETAIL  
FULL SCALE

D11A  
00.1

REVISION #1  
INCREASE SILL LENGTH  
AND ADD BRASSO COVE  
DETAIL CALLOUT FOR WINDOW D11 DETAIL

| NO. | DATE     | DESCRIPTION       |
|-----|----------|-------------------|
| 1   | 08/08/18 | ISSUED FOR PERMIT |

REVISED!  
06-2018

|                        |                  |  |     |
|------------------------|------------------|--|-----|
| LITTLE WOMEN           | EXT. MARCH HOUSE |  | 217 |
|                        | WINDOW           |  |     |
| PROJECT NO. 18-001     |                  |  | 06  |
| DATE: 08/08/18         |                  |  |     |
| DRAWN BY: J. RAYMOND   |                  |  |     |
| CHECKED BY: J. RAYMOND |                  |  |     |

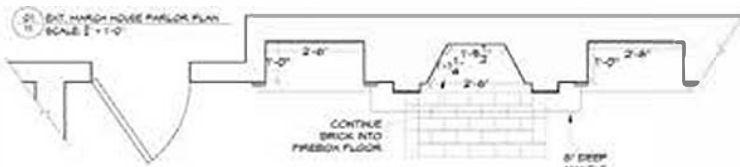

02-1 EXISTING MARCH HOUSE REF. PHOTO NOT TO SCALE



02-2 EXISTING MARCH HOUSE REF. PHOTO NOT TO SCALE

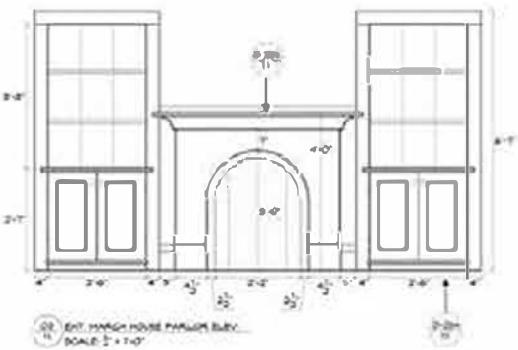

02-3 EXISTING MARCH HOUSE PARLOR BLEV. SCALE 1/2" = 1'-0"

MADE IS FOR BRICK AND HEARTH REFERENCE ONLY

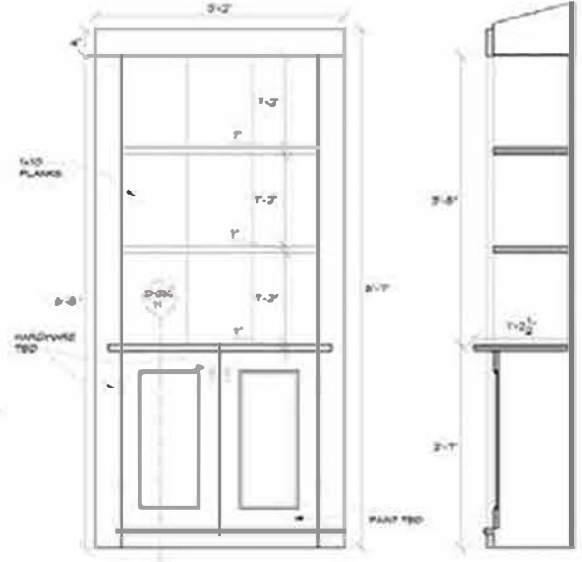

02-4 EXISTING MARCH HOUSE BUILT-IN BOOKCASE FRONT BLEV. SCALE 1/2" = 1'-0"

02-5 EXISTING MARCH HOUSE BUILT-IN BENCH BOOKCASE VERTICAL SECTION SCALE 1/2" = 1'-0"

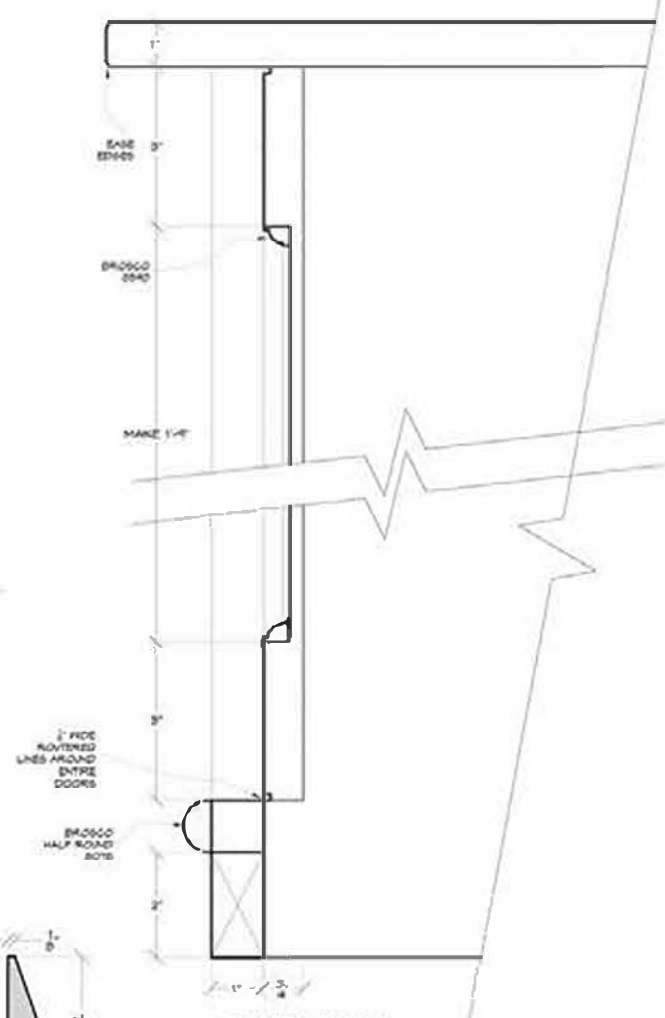

02-6 EXISTING MARCH HOUSE BUILT-IN BENCH BOOKCASE VERTICAL SECTION SCALE 1/2" = 1'-0"

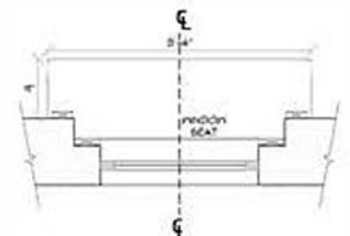

02-8 EXISTING MARCH HOUSE PARLOR ROOM BENCH SEAT SCALE 1/2" = 1'-0"

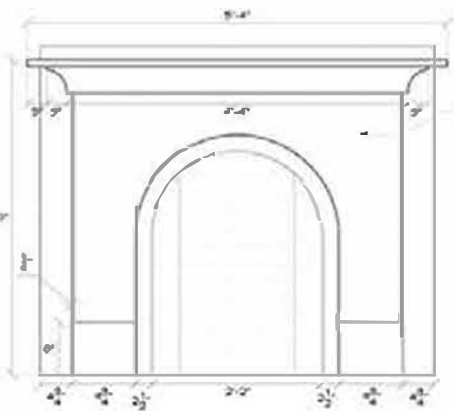

02-7 EXISTING MARCH HOUSE PARLOR ROOM PREPLAGE & MANTLE SCALE 1/2" = 1'-0"

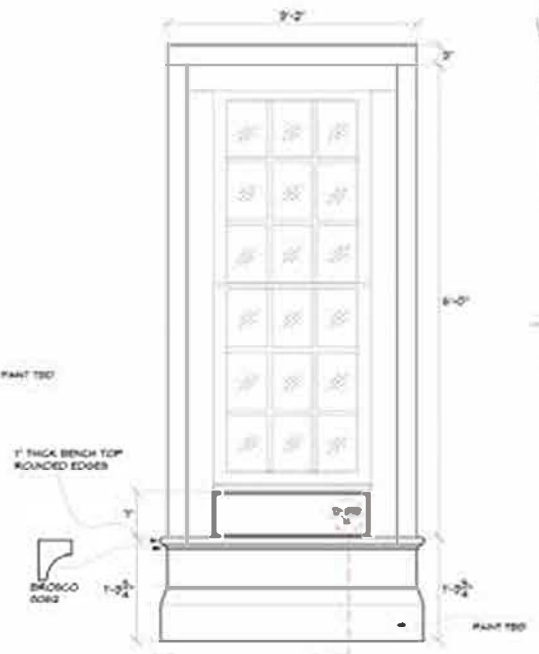

02-9 EXISTING MARCH HOUSE PARLOR ROOM BENCH SEAT SCALE 1/2" = 1'-0"

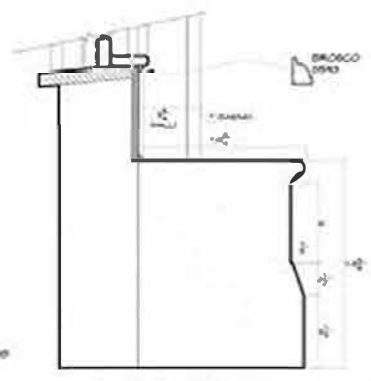

02-10 EXISTING MARCH HOUSE PARLOR ROOM BENCH SEAT INTERNAL SECTION SCALE 1/2" = 1'-0"



02-11 EXISTING MARCH HOUSE TYP. BASEBOARD FULL SCALE DETAIL



02-12 EXISTING MARCH HOUSE REF. PHOTO NOT TO SCALE

**NOTES:**  
 - ALL FLOOR TO BE PAINT GRADE  
 - ADD DISTRESS PER ART DIRECTOR  
 - EASE APPROPRIATE EDGES  
 - PAINT FINISH TBD PER P.O.

**RELEASED!**  
 02/19/2018



| SAT. MARCH HOUSE    |            | 217 |
|---------------------|------------|-----|
| PARLOR ROOM DETAILS |            |     |
| A. GARDNER          | 02/19/2018 | 11  |





LITTLE WOMEN • NEW YORK THEATRE • "TWELFTH NIGHT" SET • PRELIMINARY RENDER • 09/08/18

GREGORY



1'-0" x 1'-0" SQUARES  
@  
1"=1'-0" SCALE

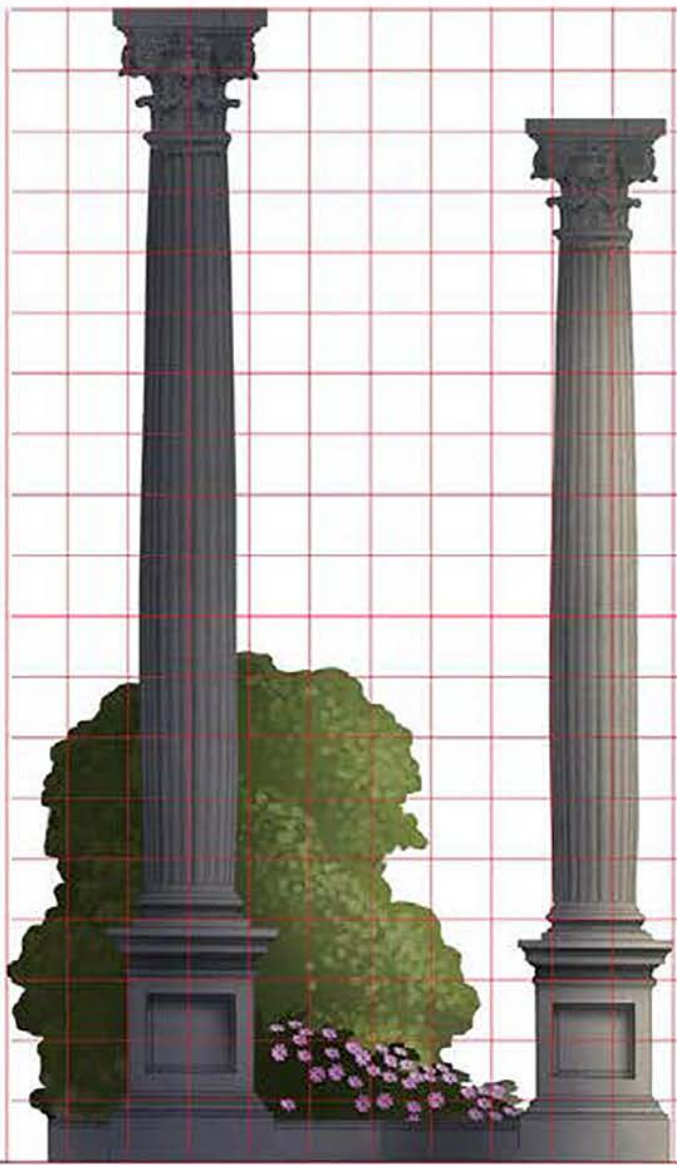

TWELFTH NIGHT • DSR RAILING (REVERSE & REPEAT FOR DSL RAILING)  
FRONT ELEVATION  
SCALE: 1"=1'-0"



GRID IS 1'-0" x 1'-0" SQUARES @ 1"=1'-0" SCALE

TWELFTH NIGHT • USR PILLAR UNIT (REVERSE & REPEAT FOR USL PILLARS)  
FRONT ELEVATION  
SCALE: 1"=1'-0"

TWELFTH NIGHT • UBR WALL (R & R FOR USL WALL)  
FRONT ELEVATION  
SCALE: 1"=1'-0"

**PRELIMINARY**

**LITTLE WOMEN • TWELFTH NIGHT SET  
GRIDDED FOR CREATING LAYOUTS**

|  |  |              |      |
|--|--|--------------|------|
|  | SET: TWELFTH NIGHT STAGE SET<br>LOCATION: Grand Theatre, Boston, MA<br>SET RECS ELEVATIONS | REV          | DATE |
|  | DRAWN BY: [Name]<br>CHECKED BY: [Name]   | REVISION     | DATE |
|  | SCALE: 1"=1'-0"<br>SHEET NO. 5   | TOTAL SHEETS | 5    |
|  | PROJECT NO. [Number]   | DATE         |      |



DSR TREE UNIT   DSR RAILING   USR WALL   USR PILLARS   USC RAILING   PAINTED DECK   USL WALL   USL PILLARS   DSL RAILING   DSL TREE UNIT



THIS IS A VIEW OF THE 3D MODEL WITH PROSCENIUM PARTIALLY CUT AWAY TO HELP SHOW ALL OF THE SCENIC ELEMENTS.

### GENERAL NOTES:

THIS SET IS MEANT TO RECREATE A TYPICAL 19th CENTURY TOURING COMPANY SET... ALL OF THE ELEMENTS ARE FLAT, PAINTED THEATRICAL FLATS WITH PROPLED EDGES ADDED.

ALL UNITS SHOULD BE COVERED WITH MUSLIN FOR PAINTING.

THE RAILINGS AND THE UPSTAGE WALL UNITS SIT ON THE THEATRE DECK AND ARE SUPPORTED BY JACKS ON THEIR UPSTAGE AND/OR OFFSTAGE ENDS.

THE TREES AND THE PILLAR UNITS WILL BE HUNG FROM THEATRE POLES AND ATTACHED TO THE DECK TO PREVENT MOVEMENT.

LITTLE WOMEN • TWELFTH NIGHT SET

RELEASED

|  |   |  |
|--|---|--|
|  | SET: TWELFTH NIGHT STAGE SET<br>LOCATION: Central Theatre, Boston, MA<br>FULL STAGE SET RENDERS | DESIGNED BY: [ ]<br>DRAWN BY: [ ]<br>DATE: [ ] |
|  | SCALE: 1/8" = 1'-0"<br>NO. OF UNITS: 1  | NO. OF UNITS: 1                                |
|  | NO. OF UNITS: 1   | NO. OF UNITS: 1                                |



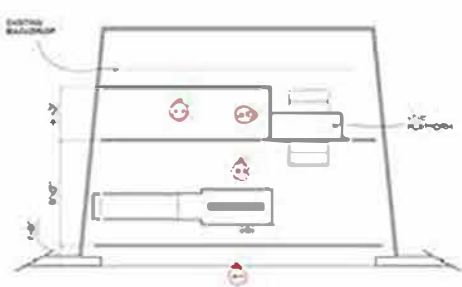

01 CONCORD THEATER MELIORAMA ELEV. A-0. SCALE: 1/4" = 1'-0"

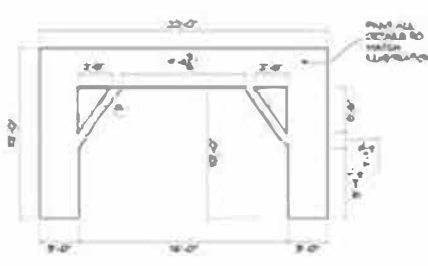

A-1 CONCORD THEATER MELIORAMA ELEV. A-1. SCALE: 1/4" = 1'-0"

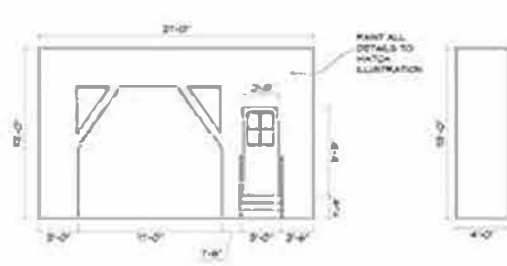

A-2 CONCORD THEATER MELIORAMA ELEV. A-2. SCALE: 1/4" = 1'-0"

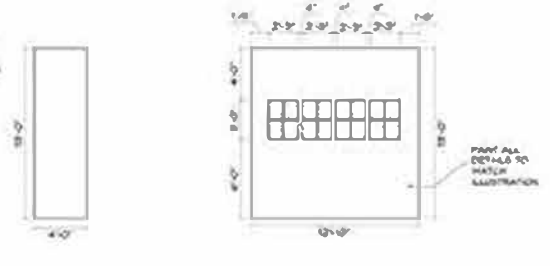

A-3 CONCORD THEATER MELIORAMA ELEV. A-3. SCALE: 1/4" = 1'-0"



02 CONCORD THEATER TABLE SAW SIDE ELEV. SCALE: 3/4" = 1'-0"

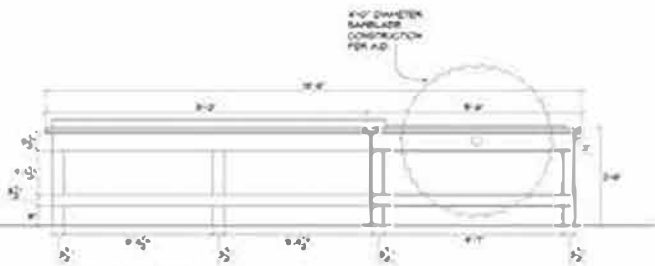

03 CONCORD THEATER TABLE SAW FRONT ELEV. SCALE: 3/4" = 1'-0"



04 CONCORD THEATER TABLE SAW BACK ELEV. NOT TO SCALE

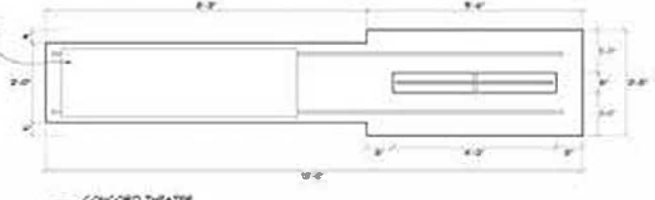

05 CONCORD THEATER TABLE SAW PLAN VIEW. SCALE: 3/4" = 1'-0"

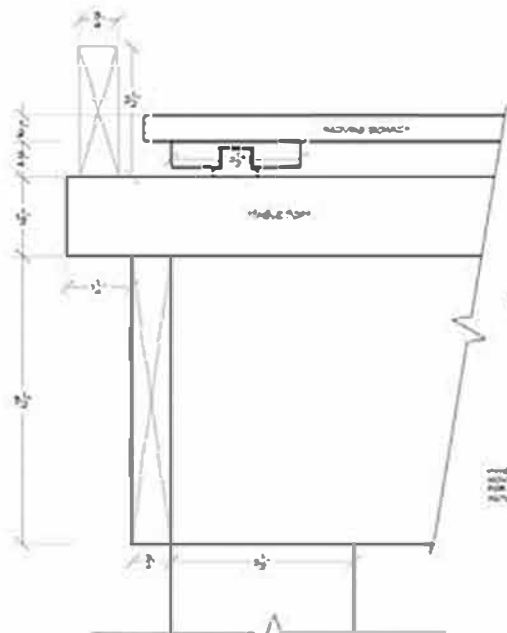

07 CONCORD THEATER SAW FRONT ELEV. SCALE: 1/4" = 1'-0"



08 CONCORD THEATER SAW LEVER FRONT ELEV. SCALE: 3/4" = 1'-0"



09 CONCORD THEATER SAW LEVER TOP ELEV. SCALE: 3/4" = 1'-0"



10 CONCORD THEATER SAW LEVER SIDE ELEV. SCALE: 3/4" = 1'-0"



11 CONCORD THEATER SAW LEVER FRONT PLAN. SCALE: 3/4" = 1'-0"

NOTES:  
- BEING PAINTED AND PAINT TO MATCH DETAILS TO MATCH ILLUSTRATION EXCEPT FOR GOLD-LEAF  
- ALL BEADS - ONE THEATER PLATE E 7/16"

**RELEASED**  
10-00-18

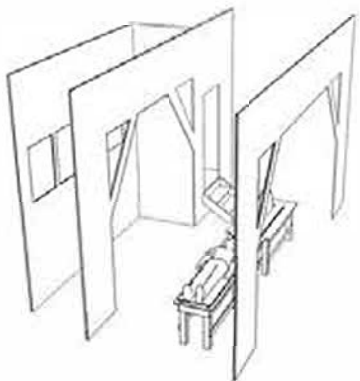

06 CONCORD THEATER MELIORAMA REF. PHOTOS. NOT TO SCALE

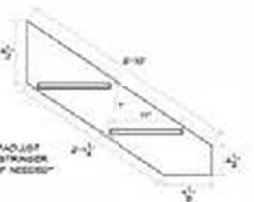

01 CONCORD THEATER MELIORAMA STAIRS. SCALE: 1/4" = 1'-0"

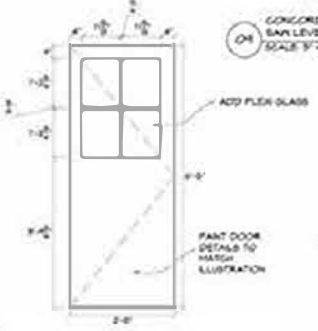

06 CONCORD THEATER MELIORAMA DOOR FLAT. SCALE: 1/4" = 1'-0"



|                              |      |
|------------------------------|------|
| BY CONCORD THEATER MELIORAMA | 2-05 |
| CONCORD THEATER MELIORAMA    | 2-05 |
| CONCORD THEATER MELIORAMA    | 2-05 |
| CONCORD THEATER MELIORAMA    | 2-05 |
| A. RAYMOND                   | 2-05 |



GREGORY HILL



GREGORY HILL



GREGORY HILL

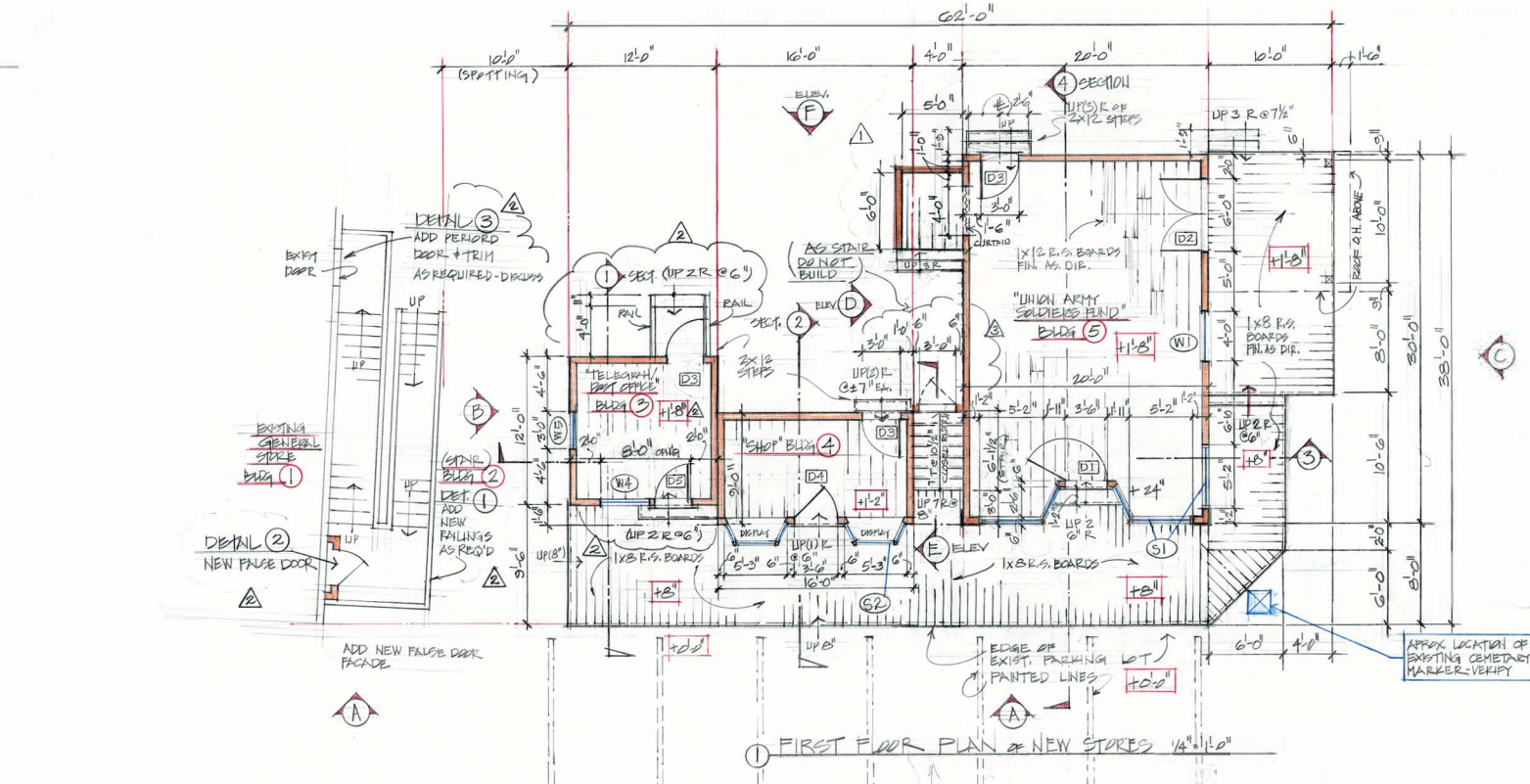
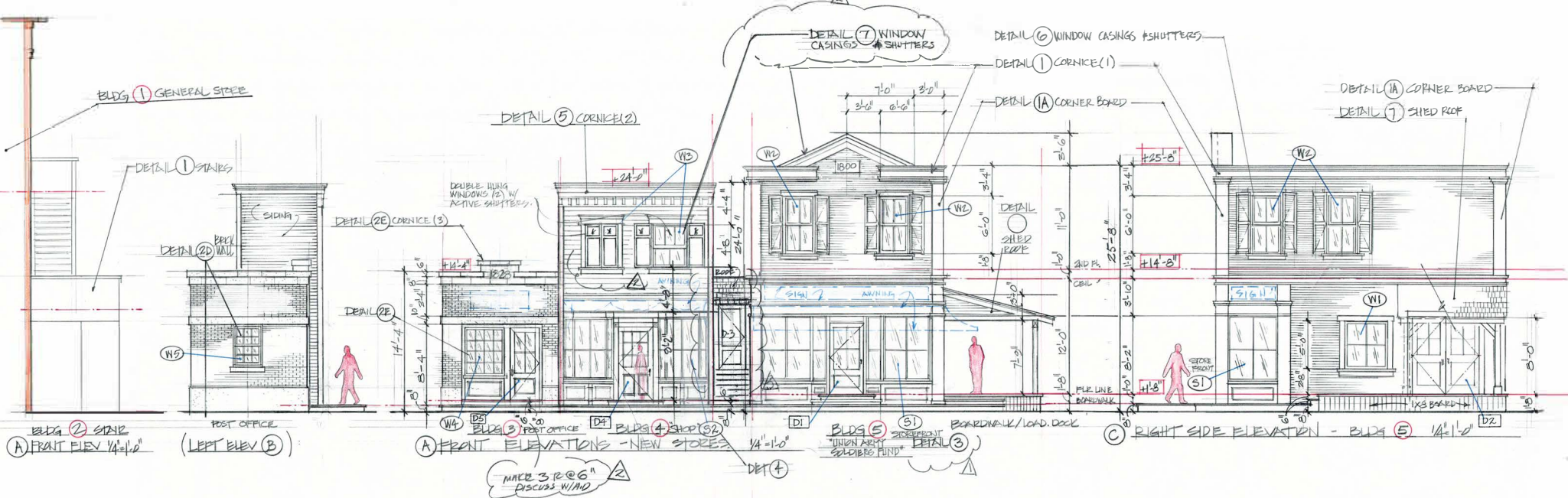

|          |         |  |         |              |
|----------|---------|--|---------|--------------|
| REVISION | 10.5.18 | DOOR AT STAIR W/ROOF                                 | DATE    | 08/14/2018   |
| REVISION | 9/26/18 | BANK FLOOR + FRONT DOOR, BLDG 4 SHUTTERS INDICATIONS | SCALE   | 1/8" = 1'-0" |
| REVISION | 9/6/18  | ADDED OPENING  | PROJECT | 3            |

|  |   |  |
|--|---|--|
|  | TITLE: CONCORD TOWN NEW FACADE<br>LOCATION: CITY OF CONCORD, MASSACHUSETTS<br>PROJECT: 1ST FLOOR PLAN - EXTENDED ELEVATIONS<br>DRAWN BY: [Name]<br>CHECKED BY: [Name]<br>DATE: 08/14/2018<br>DATE SIGNED: [Signature] | SHEET NO: 256<br>OF: 256<br>REVISION: 3<br>SCALE: 1/8" = 1'-0"<br>DATE: 08/14/2018 |
|--|---|--|





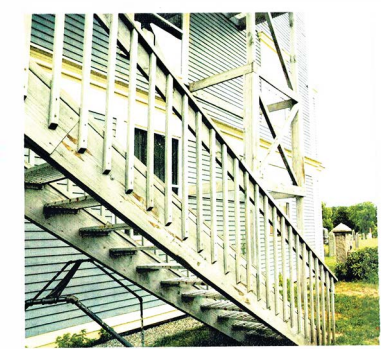
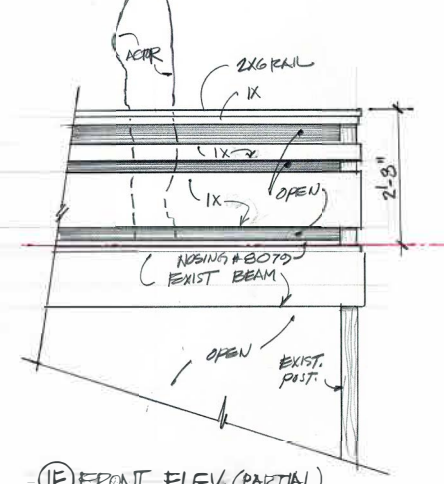
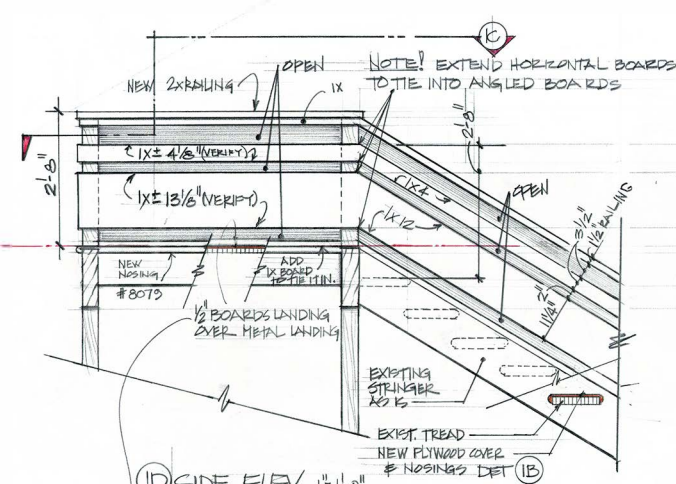

BOTTOM OF EXISTING EXT. STAIR  
N.T.S.



EXISTING GARAGE AND EXT. STAIR  
N.T.S.

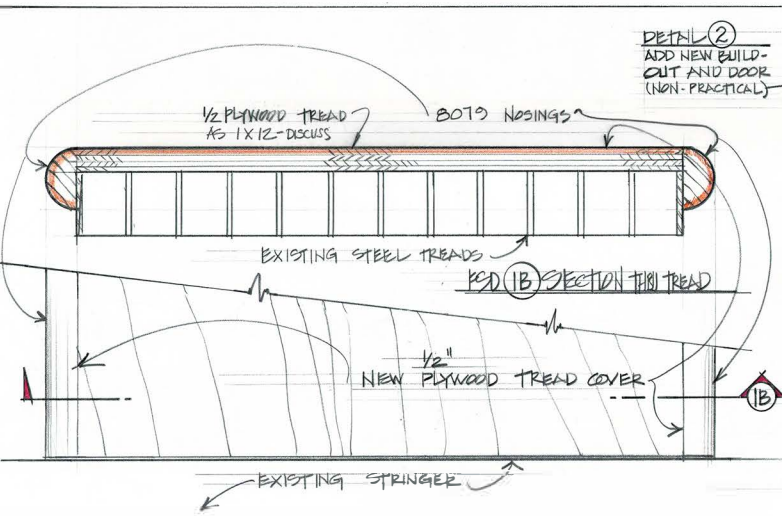
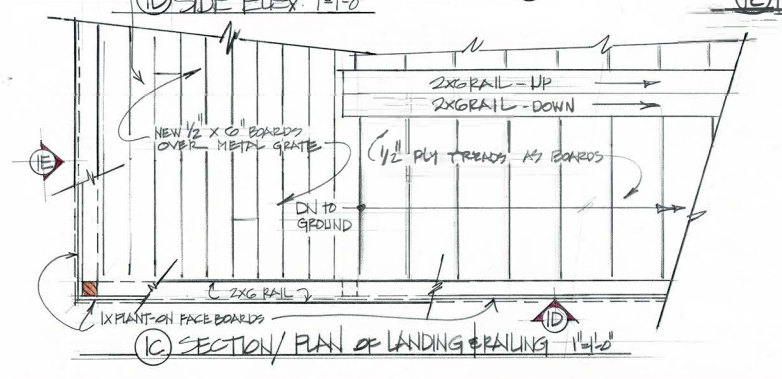

RED (A) TOP VIEW OF TREAD (TOP) COVER

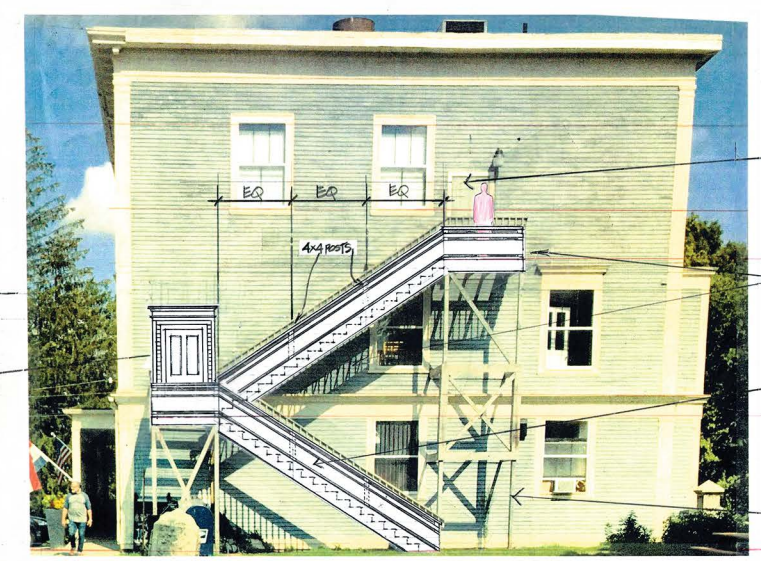

(A) SIDE ELEVATION OF GENERAL STORE 1/4"-10"

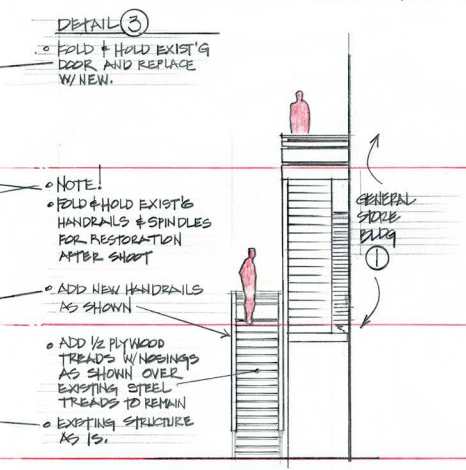

(B) SIDE ELEVATION 1/4"-10"

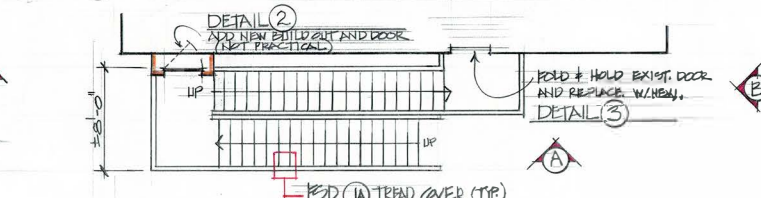

(1) PLAN OF SIDE STAIR 1/4"-10"

|  |   |                     |                     |                  |
|--|---|---------------------|---------------------|------------------|
|  | PROJECT: CONCORD TOWN - NEW PROJECT           | DATE: 05/20/2018    | SCALE: 1/4" = 1'-0" | SHEET: 32        |
|  | CLIENT: TOWN OF HAVENHILL, MASSACHUSETTS      | DATE: 05/20/2018    | SCALE: 1/4" = 1'-0" | SHEET: 32        |
|  | DESIGNER: SPURDEINSE (1) BUILDING + INTERIORS | DATE: 05/20/2018    | SCALE: 1/4" = 1'-0" | SHEET: 32        |
|  | DATE: 05/20/2018                              | SCALE: 1/4" = 1'-0" | SHEET: 32           | DATE: 05/20/2018 |



www.ksre.com



LITTLE WOMEN • CONCORD STREET • FINAL ADDITIONAL BUILDING COLOR STUDY  
DATE: 09/14/18

GREGORY HILL









10791486

500-UR-2

United Rentals

500-UR-2

NO PARKING  
IN FRONT OF  
THIS PROPERTY

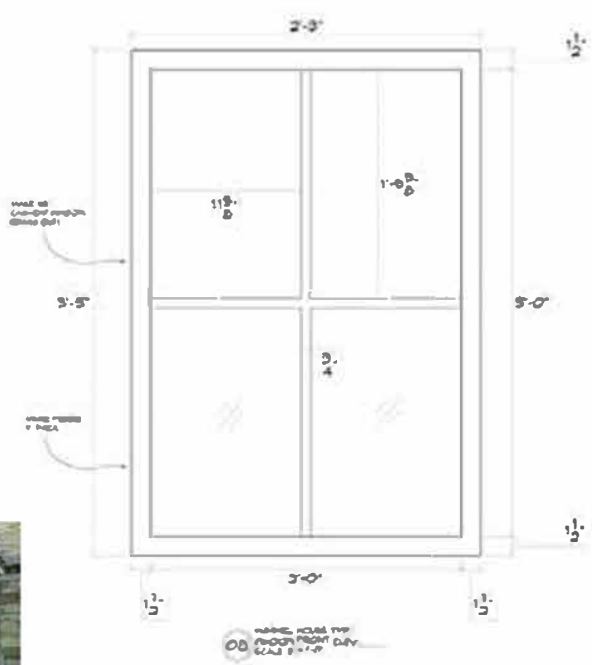
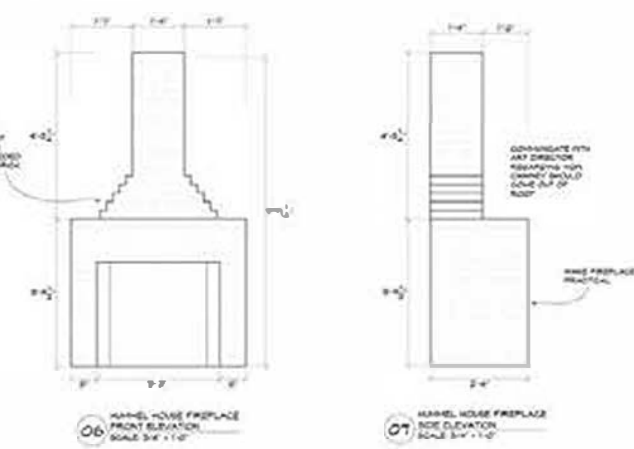
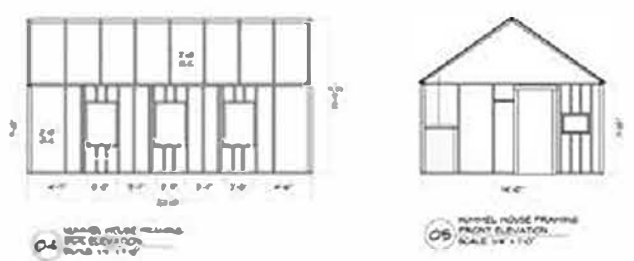
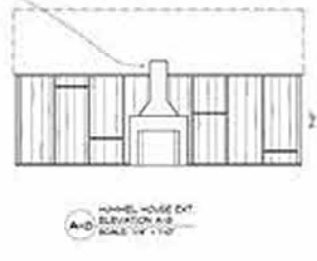
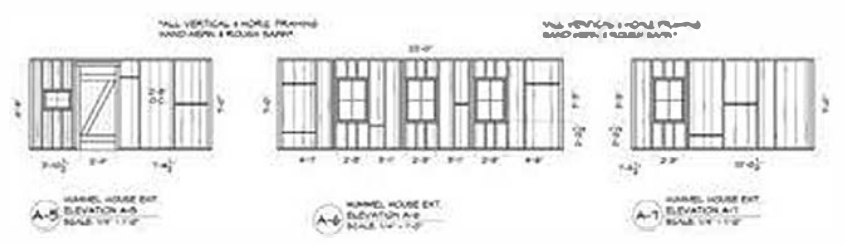
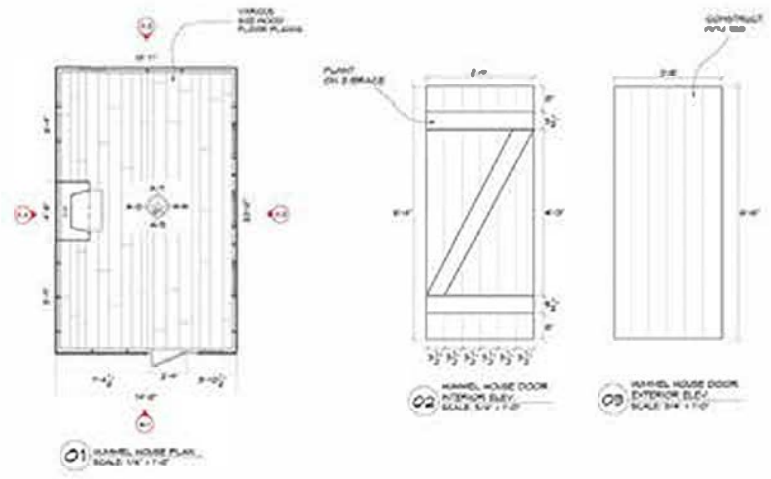
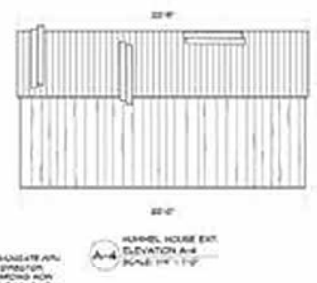
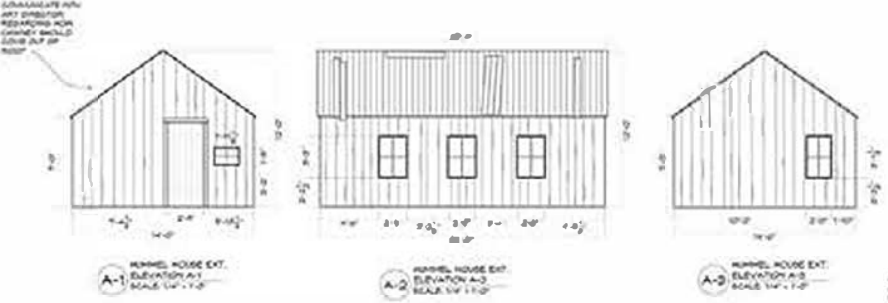

RELEASED!

NOTES  
ALL VERTICAL & HORIZONTAL DIMENSIONS FOR CORNER SHOULD COME OUT OF ROOF  
ALL DIMENSIONS TRUE

|                  |   |      |      |
|------------------|---|------|------|
|                  | HAMMEL HOUSE  |      | 2005 |
|                  | CAMP CLEAR #11<br>3110 W. 10th St. #111<br>MUSKOGEE COUNTY, GEORGIA |      |      |
| A. A. RICHARDSON |   | DATE | 01   |



